



Ravaglioli

COMPANY WITH
QUALITY SYSTEM
CERTIFIED BY DNV GL
= ISO 9001 =

SOLLEVATORI ELETTROIDRAULICI 

ELECTRO-HYDRAULIC 

ELEKTROHYDRAULISCHE HEBEBÜHNEN 

ELEVATEURS ELECTRO-HYDRAULIQUES 

ELEVADORES ELECTROHIDRAULICOS 

RAV
8055
8065
SERIES

*VERTICAL RISE
From 5500 to 6500 kg*



PLATFORMS $\frac{5400 \text{ mm}}{6000 \text{ mm}}$

New



60
SINCE 1958



1

Sollevatori con pedane piane
Lifts with flat platforms
Hebebühne mit ebenen Fahrschienen
Élévateurs avec chemins de roulement plats
Elevadores con plataformas lisas

RAV 8065.1.60 / 6500 kg / 6000 mm
 RAV 8065.1.60SI / 6500 kg / 6000 mm / LIFT TABLE

Sollevatori con pedane di grandi dimensioni e struttura portante studiata per la massima rigidità e stabilità in esercizio.

Lifts with large size platforms and sturdy structure assuring maximum rigidity and working stability.

Lange verstärkte Fahrbahnen bieten aufgrund der intelligenten Konstruktion eine hervorragende Steifigkeit.

Ponts élévateurs avec chemins de roulement de grandes dimensions et structure portante étudiée pour offrir un maximum de rigidité et de stabilité pendant le fonctionnement.

Elevadores con plataformas de grandes dimensiones y estructura portante estudiada para garantizar la máxima rigidez y estabilidad de trabajo.

RAV 8065.1.60

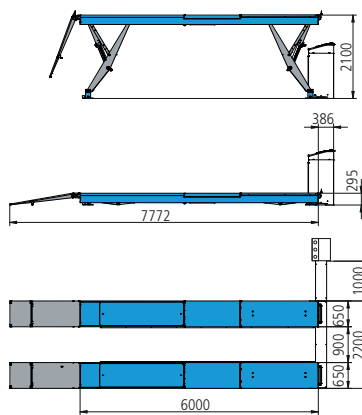

RAV 8065.1.60SI

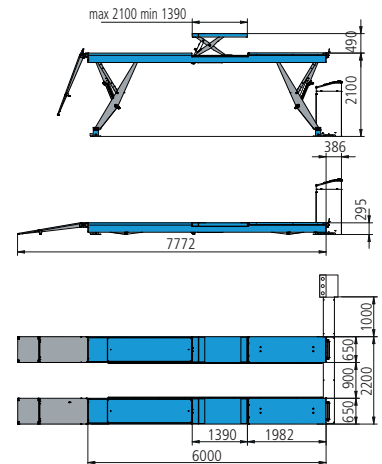

	Portata Capacity Tragfähigkeit Capacité Capacidad	Pedane Platforms Fahrschienen Plateformes Plataformas
	kg	mm
RAV8065.1.60	6500	6000
RAV8065.1.60SI		



2

Sollevatori per misurazione assetto ruote
Wheel alignment lifts
Hebebühnen für die Achsvermessung
Élévateurs pour contrôle de géométrie
Elevadores alineado de direccion

RAV 8055.2.54 / 5500 kg / 5400 mm
 RAV 8055.2.54SI / 5500 kg / 5400 mm / LIFT TABLE
 RAV 8065.2.60 / 6500 kg / 6000 mm
 RAV 8065.2.60SI / 6500 kg / 6000 mm / LIFT TABLE

Pedane per assetto totale, con sedi anteriori per piatti rotanti e piani oscillanti posteriori.

Platforms for total wheel alignment, with front turning plates locations and rear slip plates.

Achsmess-Kit in die Fahrbahnen integriert.

Chemins de roulement pour géométrie totale, avec logements avant pour plateaux pivotants et plans mobiles arrière.

Plataformas para alineación total, con asientos para platos giratorios delanteros y platos oscilantes traseros

RAV 8055.2.54

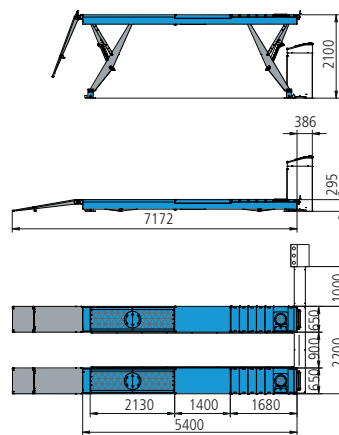

RAV 8055.2.54SI

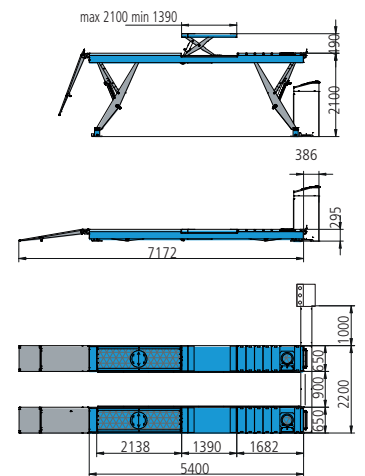

RAV 8065.2.60

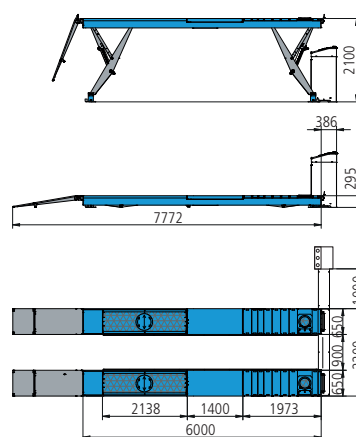

RAV 8065.2.60SI

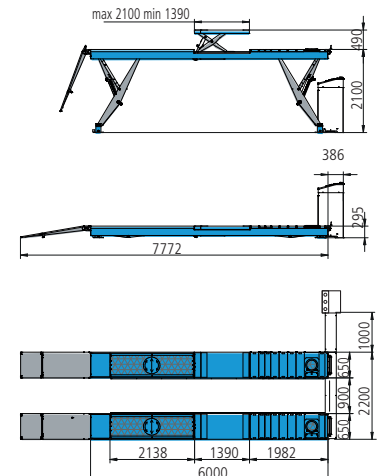

	Portata Capacity Tragfähigkeit Capacité Capacidad	Pedane Platforms Fahrschienen Plataformas Plataformas
	kg	mm
RAV8055.2.54	5500	5400
RAV8055.2.54SI		
RAV8065.2.60	6500	6000
RAV8065.2.60SI		

SI MODELS
LIFT TABLE - 4000 kg



Versioni incassate
Recessed versions
Unterflurausführungen
Versions à encastrément
Versiones empotradas

Tutti i sollevatori possono essere forniti anche in versione incassata.
All can be supplied for recessed installation.

Alle Hebebühnen können auch in Unterflur-Version geliefert werden

Tous les ponts élévateurs peuvent être fournis en version encastrée dans le sol.

Todos los elevadores se encuentran disponibles en versión empotrada.

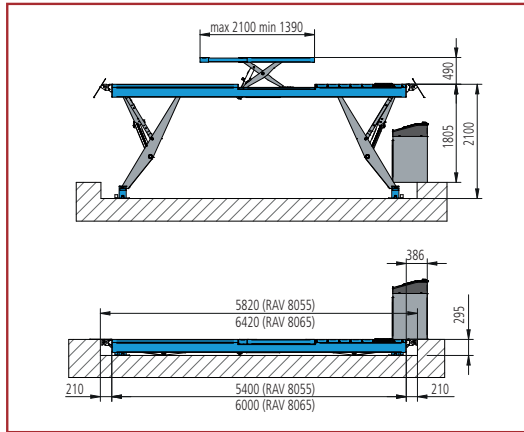

	Portata Capacity Tragfähigkeit Capacité	Pedane Platforms Fahrschienen Plateformes Plataformas
	kg	mm
RAV8065.1.60I	6500	6000
RAV8065.1.60SI		

	kg	mm
RAV8055.2.54I	5500	5400
RAV8055.2.54SI		
RAV8065.2.60I	6500	6000
RAV8065.2.60SI		

OPTIONS

Vedere documentazione specifica - See special technical specifications - Siehe spezifische Unterlagen.
 Voir documentation spécifique - Consultar documentación específica

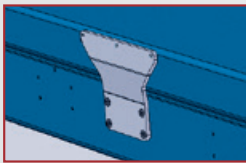

S8000A1 (2 x kit)
 Supporti per assetto 3D
 Brackets for 3D alignment
 Halter für 3D Achsmessgeräte
 Supports pour géométrie 3D
 Soportes para alineadoras 3D

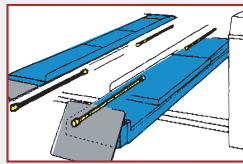

Impianto di illuminazione
 Lighting kit
 Beleuchtung
 Système d'éclairage
 Instalación de alumbrado

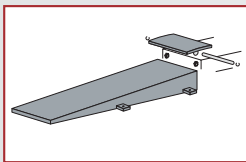

Rampe lunghe
 Longer run-up ramps
 Längere Auffahrampen
 Rampes d'accès longues
 Rampas de subida largas



Traverse
 Jacking beams
 Achsheber
 Traverses
 Gatos

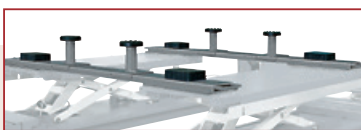

S505A2 (2 x kit)

Traverse

Indispensabili per il sollevamento in sicurezza a ruote libere di fuoristrada e veicoli particolari con punti di sollevamento su pianale ravvicinati.

Cross members

To provide safe wheel free lifting of vehicles with narrow lifting points.

Querstreben

Für ein sicheres Anheben von Geländewägen und Sonderfahrzeugen mit Radfreihebern an aneinander angenäherten Hebeupunkten auf der Hebebühne.

SI

Traverses pour véhicules spéciaux.
 Indispensables pour le levage en toute sécurité avec roues libres de véhicules tout-terrain et véhicules avec points de levage rapprochés à l'intérieur du chassis.

Traviesas para vehículos especiales.
 Indispensables para el levantamiento "ruedas libres" en condiciones de seguridad de vehículos todo terreno y vehículos con puntos de levantamiento al interior del chasis.

Set tamponi / Set of pads / Satz Klötze / Tampons / Juego de tacos (4 x kit)

- S505A1** H= 200 mm
- S505A5** H= 120 mm
- S505A9** H= 60 mm (included)
- S505A6** H= 40 mm
- S505A7** H= 20 mm

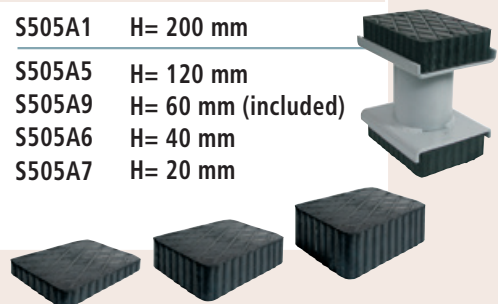

Ravaglioli S.p.A.
 via 1° maggio 3
 Fraz. Pontecchio M.
 40037 Sasso Marconi (Bo) - Italia
 Tel. +39 - 051 - 6781511
 Fax +39 - 051 - 846349
 rav@ravaglioli.com
 www.ravaglioli.com

RAV France
 4, Rue Longue Raie
 ZAC de la Tremblaié
 91220 Le Plessis Pâté
 Tel. 01.60.86.88.16
 Fax 01.60.86.82.04
 rav@ravfrance.fr

Ravaglioli Deutschland
 Kirchenpoint 22
 85354 Freising
 Tel. 08165-646956
 Fax 08165-646958
 ravid@ravaglioli.com

RAV Equipment UK LTD
 Prince Albert House
 20 King Street
 Maidenhead, SL6 1DT
 Tel. +39 - 0516781522
 rav@ravaglioli.com

RAV en Belgique
 Nederlandstalig
 Tel. 0498-162016
 Fax 016-781025
 Zone Francophone
 Tel. 0498-163016
 Fax +32 78 055 030

RAV Equipos España S.L.U.
 Avenida Europa 17
 Pol. Ind. de Constanti
 Tarragona 43120
 Tel. 977 524525
 Tel. 977 524532
 ravequipos@ravaglioli.e.telefonica.net

A DOVER COMPANY

DRD24U (5)

Le caratteristiche tecniche e gli allestimenti presentati in questo prospetto possono subire variazioni. Le immagini riprodotte non sono vincolanti.
 Technical data and composition presented in this catalogue may vary. Pictures reproduced are only indicative.
 Die techn. Daten und die Ausrüstungen, die in diesem Prospekt enthalten sind, können Änderungen erfahren. Deshalb sind die Abbildungen unverbindlich.
 Les caractéristiques techniques et les compositions présentées dans ce prospectus peuvent subir des variations. Les images reproduites n'ont qu'une valeur indicative.
 Las características técnicas y las composiciones ilustradas en este folleto pueden sufrir variaciones. Las imágenes propuestas son solamente indicativas.

